



# BEVERAGE-AIR

Project: _____	AIA#
Item: _____	
Location: _____	SIS#
Approved: _____	

**SPED48HC SANDWICH PREP: MEGA TOP SERIES**

## FOOD PREPARATION TABLES

**MODEL:  
SPED48HC-12M-4**

### SPED48HC Sandwich Prep Table Mega Top Hydrocarbon Series

**3 Year Parts/Labor Warranty  
Additional 4 Year Compressor Warranty**

#### CABINET CONSTRUCTION

- Stainless steel front, sides, top, drawer and grille (galvanized back & bottom)
- Interior liner is made of corrosion resistant aluminum
- Full electronic control
- Mega top
- Airflow assures that product in open containers is kept below 41°F and above freezing
- Snap-In magnetic gaskets for positive drawer seal
- Painted aluminum drawer handles
- 10" Wide cutting board constructed of white polyethylene plastic
- Cutting board removable for cleaning
- Twelve (12) 1/6 4" deep pans constructed of polycarbonate plastic
- Stainless steel drawer frames supported on telescoping drawer slides
- Drawer slides include locking mechanism that prevents drawers from being inadvertently pulled off cabinet
- Pans furnished are 4" deep constructed of polycarbonate plastic
- 6" Casters, with (2) brakes standard



#### OPTIONS & ACCESSORIES

- Stainless steel back
- Stainless steel interior
- Overshelves (single or double)
- Crumb catcher kit
- Richlite cutting board
- Night cover
- Bottle organizer
- Pan supports
- Pan support crossbar
- Pan configuration
- Locking Divider
- 6" legs or 3" casters
- Low profile casters
- Remote option\* (see note on back page)

#### REFRIGERATION SYSTEM

- Uses environmentally friendly, energy efficient R290 refrigerant, and meets all regulatory requirements for CARB, SNAP, DOE & more
- Adaptive defrost
- Epoxy coated evaporator coil
- Enhanced airflow maintains temperatures between 36° - 38°F



Please verify qualifying units by visiting:  
[www.energystar.gov/cfs](http://www.energystar.gov/cfs)

3779 Champion Blvd., Winston-Salem, NC 27105  
1-888-845-9800 Fax: 1-336-245-6453  
Beverage-Air.com Sales@bevair.com



# BEVERAGE-AIR

MODEL	SPED48HC-12M-4
<b>EXTERNAL DIMENSIONAL DATA</b>	
Width Overall	48"
Depth Overall	38 <sup>3</sup> / <sub>8</sub> "
Height Overall with Casters	49"
Number Drawers	4
Depth with Drawer Open 90°	47 <sup>7</sup> / <sub>8</sub> "
Drawer Opening	19 <sup>5</sup> / <sub>8</sub> " x 11 <sup>1</sup> / <sub>4</sub> " 19 <sup>5</sup> / <sub>8</sub> " x 7 <sup>1</sup> / <sub>2</sub> "
Width, Cutting Board	10"
<b>INTERNAL DIMENSIONAL DATA</b>	
NET Capacity (cubic ft.)	13.01
Internal Width Overall (in)	44"
Internal Depth Overall (in)	15 <sup>3</sup> / <sub>8</sub> "
Internal Height Usable (in)	23"
No. of Pans	12
<b>ELECTRICAL DATA</b>	
Full Load Amperes	2.0
<b>REFRIGERATION DATA</b>	
Horsepower	1/6
Capacity (BTU/Hr)	1094
<b>SHIPPING DATA</b>	
Gross Weight - Crated	360 lbs
Height - Crated	48"
Width - Crated	51"
Depth - Crated	37"

\*NOTE: Remote units are field wired and come with 6" legs.  
Refrigerant must be specified at time of order.

## Food Preparation Table - Mega Top Model: SPED48HC-12M-4

### Model Views

Required Clearance: 3 3/16" bottom & 2" rear

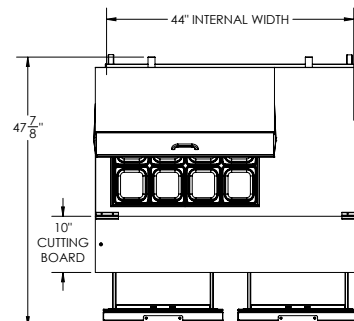

### PLAN VIEW

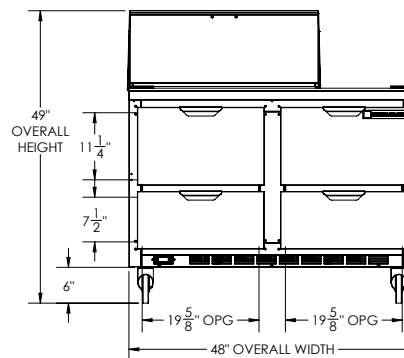

### ELEVATION VIEW

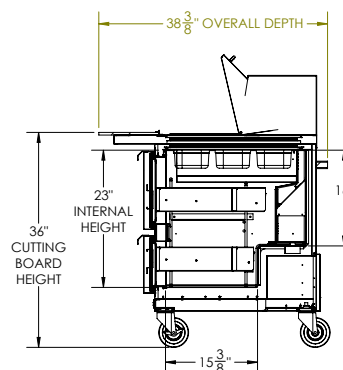

### SIDE VIEW

### \*ELECTRICAL CONNECTION



115/60/1  
NEMA 5-15P

Unit pre-wired at  
factory and include 8'  
long cord and plug set.



3779 Champion Blvd., Winston-Salem, NC 27105 1-888-845-9800 Fax: 1-336-245-6453 Beverage-Air.com Sales@bevoir.com

an Ali Group Company



The Spirit of Excellence