



BEVERAGE-AIR

Project: _____	AIA#
Item: _____	
Location: _____	SIS#
Approved: _____	

FOOD PREPARATION TABLES

MODEL:
SPE72HC-30M-DS

SPE72HC Sandwich Prep Table Mega Top With Dual-Sides Hydrocarbon Series

SPE72HC SANDWICH PREP: MEGA TOP SERIES

3 Year Parts/Labor Warranty
Additional 4 Year Compressor Warranty

CABINET CONSTRUCTION



- Stainless steel front, sides, top, doors and grille (galvanized back & bottom)
- Interior liner is made of corrosion resistant aluminum
- Full electronic control
- Mega top
- Dual-sided
- Self-closing doors with 120° Stay-open feature, on cartridge style hinges
- Easy door removal for service and cleaning
- Field-reversible doors with snap-in door gaskets
- Painted aluminum door handles
- 6" Casters, with (2) brakes standard
- 10" & 12" Wide cutting board constructed of white polyethylene plastic
- Cutting board removable for cleaning
- Two epoxy-coated steel wire shelves per door section standard
- Thirty (30) 1/6 4" deep pans constructed of polycarbonate plastic

OPTIONS & ACCESSORIES

- Stainless steel back
- Stainless steel interior
- Right or left hinged
- Locks (doors only)
- Overshelves (single or double)
- Crumb catcher
- 6" legs or 3" casters available
- Low profile casters
- Richlite cutting board
- Night cover
- Shelf dividers
- Pan supports
- Digital / stem dial thermometer
- Remote option* (see note on back page)

REFRIGERATION SYSTEM

- Uses environmentally friendly, energy efficient R290 refrigerant, and meets all regulatory requirements for CARB, SNAP, DOE & more
- Adaptive defrost
- Epoxy coated evaporator coil
- Maintains product temperatures between 36° - 38°F



Please verify qualifying units by visiting:
www.energystar.gov/cfs

3779 Champion Blvd., Winston-Salem, NC 27105
1-888-845-9800 Fax: 1-336-245-6453
Beverage-Air.com Sales@bevair.com



BEVERAGE-AIR

MODEL	SPE72HC-30M-DS
EXTERNAL DIMENSIONAL DATA	
Width Overall	72"
Depth Overall	48 1/2"
Height Overall with Casters	46 3/4"
Number Doors	3
Depth with Door Open 90°	62 3/8"
Door Opening	19 1/2" x 21 5/8"
Width, Cutting Board	10" & 12"
INTERNAL DIMENSIONAL DATA	
NET Capacity (cubic ft.)	20.02
Internal Width Overall (in)	68"
Internal Depth Overall (in)	15 3/8"
Internal Height Usable (in)	17 3/4"
No. of Shelves	6
No. of Pans	30
ELECTRICAL DATA	
Full Load Amperes	5.4
REFRIGERATION DATA	
Horsepower	1/3
Capacity (BTU/Hr)	1549
SHIPPING DATA	
Gross Weight - Crated	504 lbs
Height - Crated	38"
Width - Crated	74"
Depth - Crated	49"

*NOTE: Remote units are field wired and come with 6" legs.
Refrigerant must be specified at time of order.

Food Preparation Table - Mega Top

Model: SPE72HC-30M-DS

Model Views

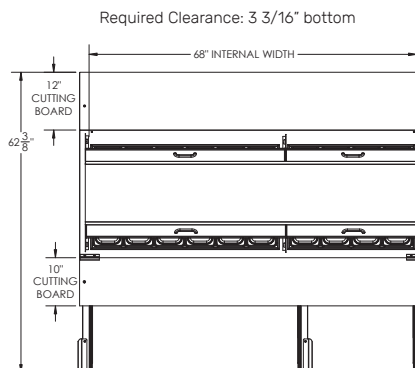

PLAN VIEW

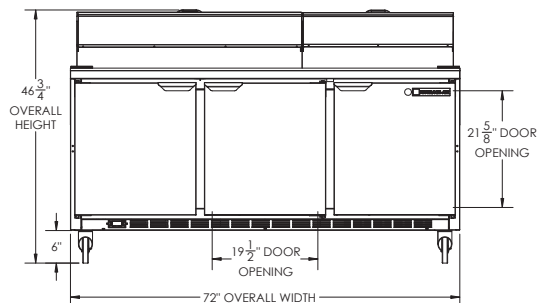

ELEVATION VIEW

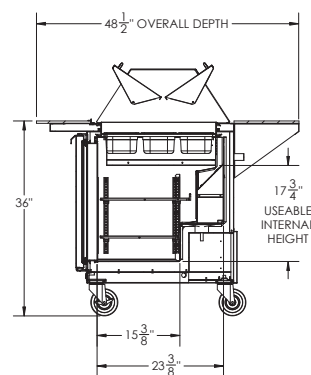

SIDE VIEW

*ELECTRICAL CONNECTION



115/60/1
NEMA 5-15P

Unit pre-wired at
factory and include 8'
long cord and plug set.



3779 Champion Blvd., Winston-Salem, NC 27105 1-888-845-9800 Fax: 1-336-245-6453 Beverage-Air.com Sales@bevoir.com

an Ali Group Company



The Spirit of Excellence