



BEVERAGE-AIR

Project: _____	AIA#
Item: _____	
Location: _____	SIS#
Approved: _____	

SPED72HC SANDWICH PREP: STANDARD TOP SERIES

FOOD PREPARATION TABLES

SPED72HC Sandwich Prep Table

Hydrocarbon Series

MODEL:
SPED72HC-08-4



3 Year Parts/Labor Warranty
Additional 4 Year Compressor Warranty

CABINET CONSTRUCTION

- Stainless steel front, sides, top, door, drawer and grille (galvanized back & bottom)
- Interior liner is made of corrosion resistant aluminum
- Full electronic control
- Removable hood made of matching stainless steel
- Airflow assures that product in open containers is kept below 41°F and above freezing
- Self-closing door with 120° Stay-open feature, on cartridge style hinges
- Easy door removal for service and cleaning
- Field-reversible door (hinge kit not included)
- Snap-In magnetic gaskets for positive door & drawer seal
- 10" Wide cutting board constructed of white polyethylene plastic
- Cutting board removable for cleaning
- Two epoxy-coated steel wire shelves per door section standard
- Eight (8) 1/6 4" deep pans constructed of polycarbonate plastic
- Pans furnished are 4" deep constructed of polycarbonate plastic
- Stainless steel drawer frames supported on telescoping drawer slides
- Drawer slides include locking mechanism that prevents drawers from being inadvertently pulled off cabinet
- 6" Casters, with (2) brakes standard

OPTIONS & ACCESSORIES

- Stainless steel back
- Stainless steel interior
- Overshelves (single or double)
- Crumb catcher kit
- Richlite cutting board
- Night cover
- Bottle organizer
- Bun rack
- Epoxy coated shelves
- Shelf clips
- Shelf dividers
- Pan supports
- Pan support crossbar
- Pan configuration
- 6" legs or 3" casters
- Low profile casters
- Remote option* (see note on back page)

REFRIGERATION SYSTEM

- Uses environmentally friendly, energy efficient R290 refrigerant, and meets all regulatory requirements for CARB, SNAP, DOE & more
- Adaptive defrost
- Epoxy coated evaporator coil
- Enhanced airflow maintains temperatures between 36° - 38°F



Please verify qualifying units by visiting:
www.energystar.gov/cfs

3779 Champion Blvd., Winston-Salem, NC 27105
1-888-845-9800 Fax: 1-336-245-6453
Beverage-Air.com Sales@bevair.com



BEVERAGE-AIR

Food Preparation Table - Standard Top Model: SPED72HC-08-4

MODEL	SPED72HC-08-4
EXTERNAL DIMENSIONAL DATA	
Width Overall	72"
Depth Overall	32"
Height Overall with Casters	45 1/8"
Number Door	1
Depth with Door Open 90°	52 1/4"
Door Opening	19 1/2" x 21 5/8"
Number Drawers	4
Depth with Drawer Open Extended	47 7/8"
Drawer Opening	19 1/2" x 11 1/4" 19 1/2" x 7 1/2"
Width, Cutting Board	10"
INTERNAL DIMENSIONAL DATA	
NET Capacity (cubic ft.)	20.0
Internal Width Overall (in)	68"
Internal Depth Overall (in)	15 3/8"
Internal Height Usable (in)	16"
No. of Shelves	2
No. of Pans	8
ELECTRICAL DATA	
Full Load Amperes	5.4
REFRIGERATION DATA	
Horsepower	1/3
Capacity (BTU/Hr)	1549
SHIPPING DATA	
Gross Weight - Crated	450 lbs
Height - Crated	46"
Width - Crated	75"
Depth - Crated	33"

*NOTE: Remote units are field wired and come with 6" legs.
Refrigerant must be specified at time of order.

Model Views

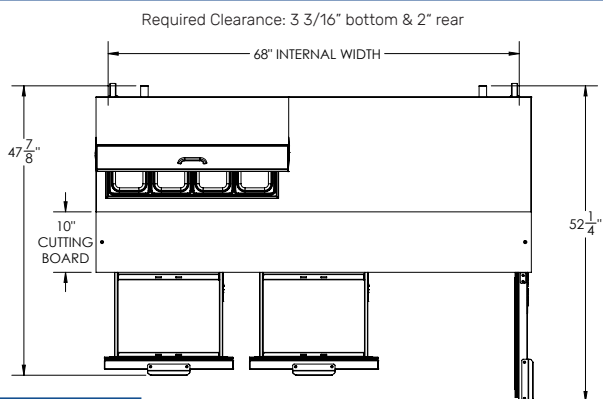

PLAN VIEW

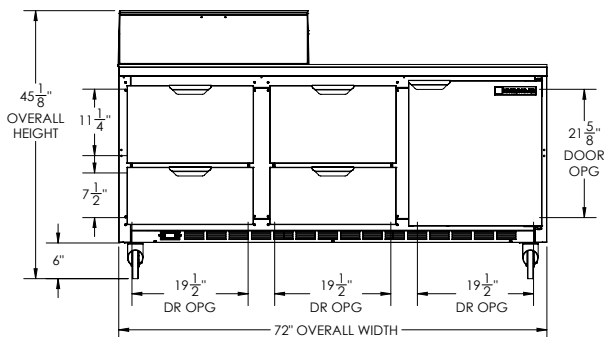

ELEVATION VIEW

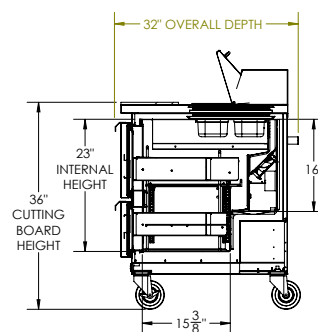

SIDE VIEW

*ELECTRICAL CONNECTION



115/60/1
NEMA 5-15P

Unit pre-wired at
factory and include 8'
long cord and plug set.



3779 Champion Blvd., Winston-Salem, NC 27105 1-888-845-9800 Fax: 1-336-245-6453 Beverage-Air.com Sales@bevoir.com

an Ali Group Company



The Spirit of Excellence