

# OPEN AIR MERCHANDISERS

## HORIZONTAL · 35" DEEP · SHORT

Project Name: \_\_\_\_\_

Project Location: \_\_\_\_\_

Model #: \_\_\_\_\_ Quantity: \_\_\_\_\_

Available Warehouse: \_\_\_\_\_

### EOMH Series Model: EOMH-36-W-35-S

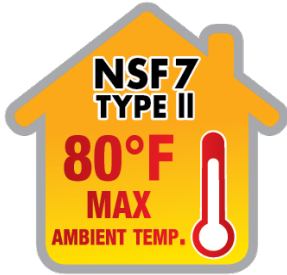

#### Refrigeration System

- Bottom mounted, self-contained and fully detachable Blizzard R290 condensing unit uses environmentally friendly, EPA-compliant R290 refrigerant with zero (0) Ozone Depletion Potential (ODP) and three (3) Global Warming Potential (GWP). Blizzard R290 is easily replaceable and requires no on-site brazing.
- Front air intake and rear air discharge design allows side by side installation.
- Conforms to **NSF Standard 7 TYPE II (maximum ambient temperature 80°F)**.
- Electronically commutated (ECM) evaporator fan motors achieve rapid cooling with less energy consumption.
- High performance, auto-reverse condenser fan motor supports compressor ventilation and condenser coil cleaning. Refer to owner's manual for full maintenance instructions.
- Large capacity, corrosion-resistant condenser and evaporator coils.
- Self-maintaining, energy-efficient condensate drain pan requires no external drains or electric heaters.
- Pre-wired and ready to plug, 115V/60Hz/1Ph, NEMA 5-20P.

#### Cabinet Construction

- Black or white modern exterior has moisture-resistant panels and field-replaceable tempered glass.
- Heavy-duty stainless steel interior has perforated back wall for efficient air flow. Includes floor drains for ease of cleaning.
- Galvanized steel top, bottom and rear.
- 2.5" thick high-density polyurethane insulation.
- Integrated retractable night curtain saves energy and provides security.
- 5" swivel casters with locks on front set. Leg stabilizers standard for all models.

#### Lighting

- Shielded LED bar lighting under shelves and canopy provide bright, high color illumination at lower heat output. On/off switch saves energy.

#### Shelving

- Removable 2-tier stainless steel shelf riser.

#### Temperature Control

- Factory preset temperature of 35°F maintains a combined average product temperature of 40°F or less.
- Audible overheat protection alarm for compressor and condenser coil.

#### Recommended Operating Conditions

- **Conforms to NSF standard 7 TYPE II designed to operate in an air-conditioned environment where temperature and humidity do not exceed 80°F and 55% relative humidity.**
- Must not be installed near ventilation systems, fans or exterior doors or windows that will disrupt the air curtain and compromise the function of the cabinet.
- Must not be installed in direct sunlight.
- In built-in applications, a distance of 6" is required on the front, back and top exterior for ventilation purposes.



Please visit our website for updated Energy Efficiency information

Ref/ Frz/Dual	Capacity Cu. Ft.	Shelves	NEMA Config	Refrigerant	HP	Power V-Hz-Ph	Amps	Crated Weight	Exterior Dimensions		
									L	D	H*
REF	5.6	-	NEMA 5-20P	R290	1/2	115-60-1	7.03	- lbs (0kg)	37.25" (946mm)	34.25" (870mm)	41" (1041mm)

(†)Based on evaporating temperature of 23°F (-5°C) & condensing temperature of 131°F (55°C). (►) Product capacity is calculated based on standard industry figures. (✳) Reference plan view for clarification on caster/unit height. If dimensions and capacity are critical, please contact Everest Refrigeration. Blizzard R290 replacement is at the sole discretion of Everest Refrigeration. Specifications subject to change without notice.

# OPEN AIR MERCHANDISERS

## HORIZONTAL · 35" DEEP · SHORT

### EOMH Series Model: EOMH-36-W-35-S

#### DIMENSIONAL DATA

External Dimensions	L	37.25" (946mm)
	D	34.25" (870mm)
	H*	41" (1041mm)
Crated Weight		- lbs. (0kg)
Doors/Drawers/Lids		-
Max Weight Support (LBS)		-

#### STORAGE DATA

Net Capacity Cu. Ft. ▶	5.6
Shelves	-
Barrels	-
20 oz. Bottles	-
12 oz. Bottles	-
12 oz. Cans	-
8" Mugs	-
# of Pans (Top)	-
# of Pans (Drawer)	-
Dividers	-
Trays	-

#### ELECTRICAL DATA

Voltage	115-60-1
Full Load Amperage	7.03A
Feed Wires with Ground	3
Cord Length	9ft
NEMA Plug Type	Ⓢ NEMA 5-20P

#### REFRIGERATION DATA

Compressor Mounting	Bottom
Refrigerant	R290
Compressor HP	1/2
BTU/HR †	-

#### KEY

D	Door	R	Refrigerator
L	Lid	REF	Refrigerator
H	Half Door	F	Freezer
FD	Full Door	FRZ	Freezer
SD	Solid Door	DUAL	REF/FRZ Combo
GD	Glass Door	DR	Drawer

	Elevation	Right	Plan	3D	Back

#### PLAN VIEW

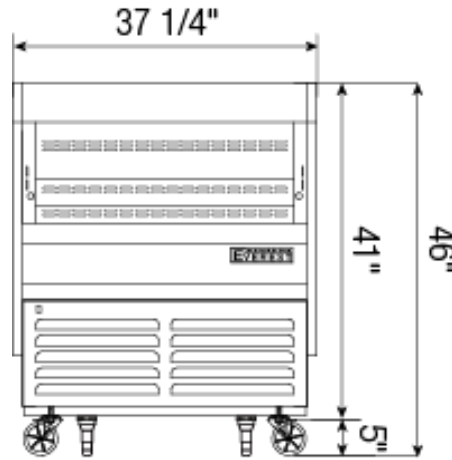

FRONT

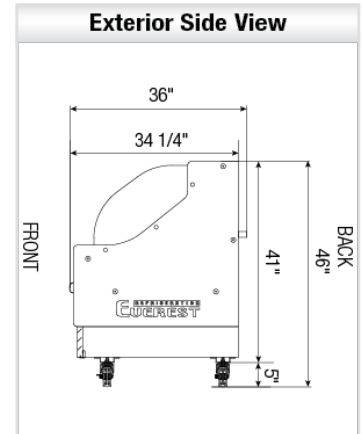

SIDE

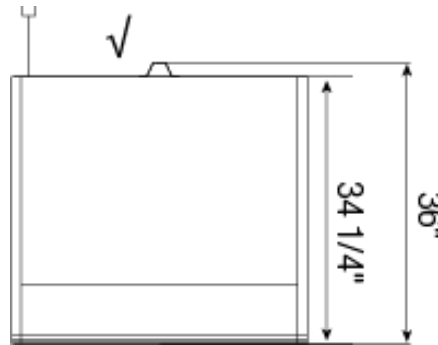

TOP

#### ACCESSORIES & OPTIONS

Part Number	Description
-------------	-------------

(†)Based on evaporating temperature of 23°F (-5°C) & condensing temperature of 131°F (55°C). (▶) Product capacity is calculated based on standard industry figures. (✖) Reference plan view for clarification on caster/unit height. If dimensions and capacity are critical, please contact Everest Refrigeration. Blizzard R290 replacement is at the sole discretion of Everest Refrigeration. Specifications subject to change without notice.