



## Undercounter Glasswasher **CO-402W**

### CO-402W High temp glasswasher - Undercounter



#### Production:

22 racks  
Standard rack size 16" x 16"

#### Functions and Benefits

Fagor's Concept range of dishwashers combines features and benefits that only high-end ranges are offering, establishing a product easy to use and efficient, with the most effective and robust technology prepared for the strongest usage of the market. Built with durable stainless steel, electromechanical components and simple digital controls with temperature display for a user-friendly operation.

- **Effi Wash:** Optimized hydraulic system provides a strong mechanical action combined with the optimum clean water in the tank. Balanced power keeps the perfect sanitation temperature during the cycle of the wash.
- **Soft Start:** Wash-pump power control that prevents wares from damage at the beginning of the washing cycle while assuring a low noise level in your facility.
- **Digital Controls:** Simple digital control panel with temperature display for intuitive and user-friendly operation, IPX-4 proof.

#### Construction

- Heavy duty stainless steel construction front, top and sides.
- **Double skin door** to reduce noise during operations.
- AISI-304 Stainless.
- **IPX4** - Stronger protection against water hose cleaning and external humidity.
- Built-in **drain pump, detergent and rinse aid dispenser.**
- Built-in **pressure gauge.**

#### Accessories

- Racks for glasses
- Rack dividers
- Cutlery containers and grids
- 6" & 16" high base stands
- Drain tempering valve



QUICK VIEW	
Dimensions: W x D x H	18 1/2" x 20 5/8" x 29 1/8"
Weight : net/crated (lbs)	86 / 97
Voltage	208-230V/1Ph/60Hz
Total Power	3.2 KW
Wash pump ( HP )	1/3
Water Consumption Per Rack	0.53 Gal.
Water Consumption Per Hour (Max)	11.66 Gal.

### SHORT FORM SPECIFICATION

The unit provided to be a Fagor EVO Concept glasswasher model CO-402W. The Concept glasswasher comes with Effi Wash, Soft Start and Digital Controls.

The unit is constructed with ANSI 304 stainless steel. IPX4 - Protection against water jets on control panel. Built-in drain pump, detergent and rinse aid dispensers. Pressure gauge. 10 5/8" clearance.

Each unit comes standard with two (2) flat racks, one (1) cutlery container and one (1) supplement for dishes.



Undercounter Glasswasher **CO-402W**

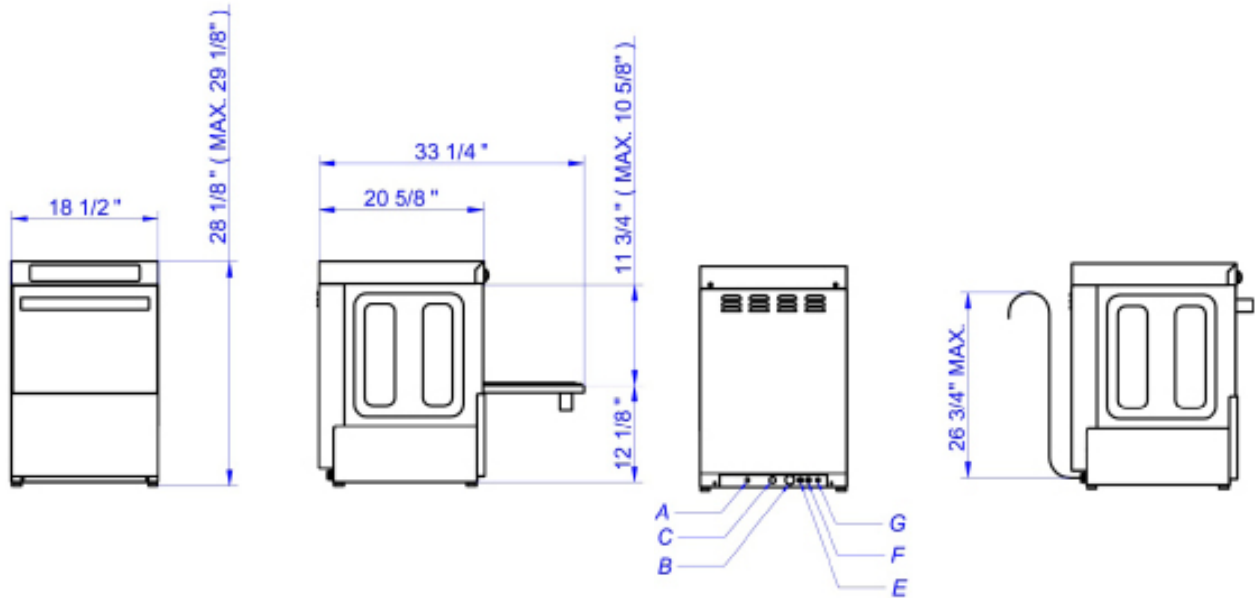

A	B	C	D	E	F	G
Water inlet *	Drain hose **	Power supply cable, strain relief ***	Terminal box	Rinse aid inlet	Detergent inlet	Equipotential bond****
<p>* Water inlet 3/4" female hose connector on 5' long flexible hose supplied with machine. Adaptor for 3/4" female garden hose fitting also supplied. 120°-140°F optimum water temperature; 20 -25 psi flow rinse pressure.</p> <p>** Drain 5' long, 1/2" I.D. flexible hose. Maximum 26 3/4" drain height permits indirect connection to drain pump.</p> <p>*** 6' Long power cord supplied with machine (NEMA 6-20P)</p> <p>**** Protection from dangerous potential differences</p>						

SPECIFICATIONS	CO-402W	
Wash Cycles (seconds)	90-120-180	
Max Productivity (*)		
Racks/hour	22	
Dishes/hour	550	
Glasses/hour	792	
Standard Rack size (inches)	15 3/4 x 15 3/4	
Weight : Net/Crated (lbs)	86 / 105	
Dimensions (inches)		
	Unit	Shipping
Width	18 1/2	21
Depth	20 5/8	26
Height	29 1/8	36
Useful Loading Height (clearance)	10 7/8	
Capacity (gallons)		
Wash Tank	3.43	
Boiler	1.05	
Water consumption per cycle	0.53	
Noise level (dBA)	<70	

SPECIFICATIONS	CO-402W	
Wash pump motor ( HP )	1/3	
Power (kW)		
Tank heating element	2	
Boiler/Booster heating element	2.8	
Wash pump(s)	0.26	
Total power	3.2	
Minimum Working Temperature		
Washing (°F)	150	
Rinsing (°F)	180	
AMP for 60 Hz		
Volts	1 Phase	
208	13 Amp	
220	14 Amp	
240	15 Amp	
Water Protection Rating	IPx4	
Detergent & rinse aid dispenser	●	
Drain pump	●	
Power cord supplied	●	

(\*) Assumed 25 dishes and 30 glasses per rack.

The manufacturer reserves the rights to modify materials and specifications without notice.