



## MODELS

KFM-OF-(40, 50, 60, 80, 100, 120)-S

KFM-OF-(40, 50, 60, 80, 100, 120)-R

**OPEN FRONT DELI CASE  
DESIGNED FOR FRESH MEAT**

CASE HOLDS 33°F TO 40°F • LOW VELOCITY FORCED AIR REFRIGERATION MAINTAINS HIGH HUMIDITY  
TEMPERED FRONT & SIDE GLASS • CASES CAN BE MULTIPLEXED



Intertek



Intertek



AUTODESK®  
REVIT®

SELF CONTAINED	Model	O.A. Length (inches)	Volume FT <sup>3</sup>	Electrical 115 Volts					NEMA 115 V Plug	Weight lbs		Crate Size (inches)		
				Compressor		LIGHTS Fans HTRS	EVAP PAN	Total Amps		No Crate	With Crate	L"	W"	H"
				H.P	F.L.A									
	KFM-OF-40-S	40.4	6.07	3/8	8.4	0.65	3.3	12.38	5-15P	285	445	48	44	42
	KFM-OF-50-S	52.2	8.00	1/2	9.6	0.65	3.3	13.58	5-15P	322	505	59	44	42
	KFM-OF-60-S	60	9.29	1/2	9.6	0.75	3.3	13.68	5-15P	365	564	67	44	42
	KFM-OF-80-S	77.5	12.15	5/8	8.9	1.20	3.3	13.43	5-15P	451	714	85	44	42
	KFM-OF-100-S	101.2	16.00	3/4	16	1.30	3.3	20.63	N/A	565	844	109	44	42
	KFM-OF-120-S	117	18.58	3/4	16	1.40	3.3	20.73	N/A	680	1053	124	44	42

REMOTE	Model	O.A. Length (inches)	115 Volts Total Amps	B.T.U	Weight lbs	
					No Crate	With Crate
					KFM-OF-40-R	40.4
KFM-OF-50-R	52.2	0.2	3015	267	450	
KFM-OF-60-R	60	0.3	3159	311	509	
KFM-OF-80-R	77.5	0.3	4345	419	681	
KFM-OF-100-R	101.2	0.4	5112	511	789	
KFM-OF-120-R	117	0.5	5472	615	988	

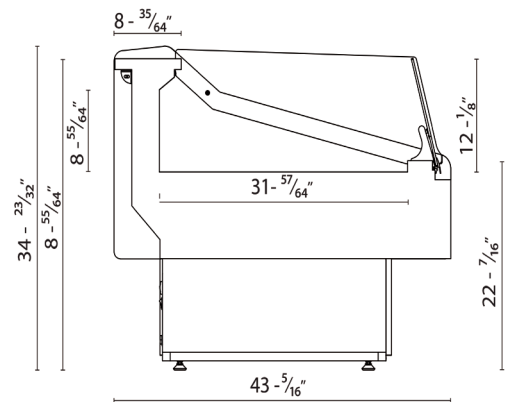

**STANDARD FEATURES**

- CFC free injected foam insulation
- Silver colored PVC coated steel front panel
- PVC coated steel gray interior
- Black steel kick plate
- Stainless steel rear work bench
- Foamed polystyrene black end panels
- Temperature and defrost regulated by a digital controller
- Removable condensate evaporating pan for easy cleaning on self contained units
- Slide out condensing unit on self-contained units
- Digital thermometer
- Leveling feet

**OPTIONAL FEATURES**

- Stainless steel exterior
- Other colors available
- Joining Kit and/or Partition
- Condensate evaporating pan for remote cases
- White epoxy bi-level wire racks 2 or 3 level step sham
- Scale stand with receptacle
- Knife support and Cutting board
- Casters add 4-3/8" to height
- Stainless steel legs are adjustable from 5-1/8" to 7-5/8"

Standard Mounting



Leveling Feet

Optional Mounting



Adjustable Legs



Casters

**NOTE**

These cases are engineered to operate in locations not exceeding 75°F and 55% R.H. These cases are designed to operate using R452a refrigerant. Alternate refrigerants available by special order. O.A. length includes (2) ends at 1-1/2" each. Ventilation grills at front and back cannot be blocked. B.T.U.'s are calculated at 14°F (evaporator) and 90°F (ambient). Remote cases are provided with an expansion valve and a liquid solenoid for pump down cycle. On remote cases, if no floor drain is provided, a condensate evaporating pan must be ordered and 3.3 amps added to the amp load. Remote cases must be hard wired – no plugs.

**WARRANTY**

One year parts and labor with an additional four years on the compressor (part only)



3560 NW 56th St  
Fort Lauderdale, FL USA 33309  
Tel: 786.600.4687 / Toll Free: 844.218.8477 / Fax: 786.661.4100



5659 Royalmount Ave.  
Montreal, QC, Canada H4P 2P9  
Tel: 514.737.9701 / Toll Free: 888.275.4538 / Fax: 514.342.3854  
Toll free: 877.453.8832  
sales@mvpgroupcorp.com / mvpgroupcorp.com

