

## MODELS

KFM-SF-(40, 50, 60, 80, 100, 120)-S

KFM-SF-(40, 50, 60, 80, 100, 120)-R

**FLAT GLASS SEAFOOD  
DESIGNED FOR FRESH FISH**

CASE HOLDS 33°F TO 40°F • LOW VELOCITY FORCED AIR REFRIGERATION MAINTAINS HIGH HUMIDITY  
TEMPERED SIDE GLASS AND REAR SLIDING DOORS • CASES CAN BE MULTIPLEXED  
INTEGRATED, NON-REMOVABLE HEAVY-DUTY ICE PAN • CASES REQUIRE FLOOR DRAINS\*



AUTODESK®  
REVIT®

SELF CONTAINED	Model	O.A. Length (inches)	Volume FT <sup>3</sup>	Electrical 115 Volts				NEMA 115 V Plug	Weight lbs		Crate Size (inches)		
				Compressor		LIGHTS Fans HTRS	Total Amps		No Crate	With Crate	L"	W"	H"
				H.P	F.L.A								
	KFM-SF-40-S	40.4	15.35	3/8	8.4	0.95	9.35	5-15P	350	512	48	44	42
	KFM-SF-50-S	52.2	20.22	1/2	9.6	0.95	10.56	5-15P	399	582	59	44	42
	KFM-SF-60-S	60	23.47	1/2	9.6	1.08	10.66	5-15P	452	650	67	44	42
	KFM-SF-80-S	77.5	30.70	5/8	8.9	1.68	10.58	5-15P	562	825	85	44	42
	KFM-SF-100-S*	101.2	40.45	2x1/2	2x9.6	2x0.96	2x10.6	2x5-15P	697	974	109	44	42
	KFM-SF-120-S*	117	46.95	2x1/2	2x9.6	2x1.08	2x10.7	2x5-15P	831	1204	124	44	42

\*Please note:

KFM-SF-100-S, KFM-SF-120-S

KFM-SF-100-R, KFM-SF-120-R

Units require two power outlets and two drains

Units are multiplexed and joined together in

the center – 100" and 120"

#### STANDARD FEATURES

Coated evaporator coil

Integrated, non-removable heavy-duty ice pan

Stainless steel frame

Stainless steel interior

Stainless steel rear work bench

CFC free injected foam insulation

Silver colored PVC coated steel front panel

Stainless steel rear work bench

Black steel kick plate

Foamed polystyrene black end panels

Tempered tilt forward front glass

Removable rear tempered glass sliding door

LED lighting in canopy

Temperature and defrost regulated by a digital controller

Slide out condensing unit on self-contained units Digital

thermometer

Levelling feet

#### OPTIONAL FEATURES

Stainless steel exterior

Cutting board

Knife Support

Other colors available

Joining Kit

Partition

Scale stand with receptacle

Casters add 4-3/8" to height

Stainless steel legs are adjustable from 5-1/8" to 7-5/8"

REMOTE	Model	O.A. Length (inches)	115 Volts Total Amps	B.T.U	Weight lbs	
					No Crate	With Crate
	KFM-SF-40-R	40.4	0.5	2548	295	456
	KFM-SF-50-R	52.2	0.51	3015	344	526
	KFM-SF-60-R	60	0.63	3159	397	595
	KFM-SF-80-R	77.5	0.78	4345	529	791
	KFM-SF-100-R*	101.2	0.91	5112	642	919
	KFM-SF-120-R*	117	1.16	5472	765	1138

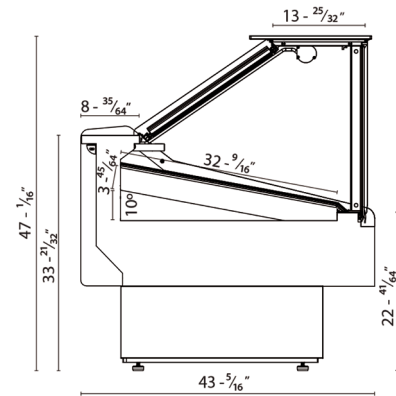

Standard Mounting



Levelling Feet

Optional Mounting



Adjustable Legs



Casters

#### NOTE

These cases are engineered to operate in locations not exceeding 75°F and 55% R.H. These cases are designed to operate using R452a refrigerant. Alternate refrigerants available by special order. O.A. length includes (2) ends at 1-1/2" each. Ventilation grills at front and back cannot be blocked. B.T.U.'s are calculated at 14°F (evaporator) and 90°F (ambient). Remote cases are provided with an expansion valve and a liquid solenoid for pump down cycle. Remote cases must be hard wired – no plugs.

#### WARRANTY

One year parts and labor with an additional four years on the compressor (part only)



3560 NW 56th St

Fort Lauderdale, FL USA 33309

Tel: 786.600.4687 / Toll Free: 844.218.8477 / Fax: 786.661.4100



5659 Royalmount Ave.

Montreal, QC, Canada H4P 2P9

Tel: 514.737.9701 / Toll Free: 888.275.4538 / Fax: 514.342.3854

Toll free: 877.453.8832

sales@mvpgroupcorp.com / mvpgroupcorp.com

