



REFRIGERATED REAR STORAGE

MODELS

KPM-FG-(60, 80, 100)-S

KPM-FG-(60, 80, 100)-R

**FLAT GLASS DELI CASE DESIGNED FOR
DELI PRODUCTS AND PACKAGED MEAT**

CASE HOLDS 33°F TO 40°F • FORCED AIR REFRIGERATION • TEMPERED TILT-OUT FLAT FRONT GLASS
TEMPERED SIDE GLASS AND REAR DOOR AND REFRIGERATED REAR STORAGE
CASES CAN BE MULTIPLEXED



AUTODESK®
REVIT®

SELF CONTAINED	Model	O.A. Length (inches)	Volume FT ³		Electrical 115 Volts						NEMA 115 V Plug	Weight lbs		Crate Size (inches)		
			Front	Rear	Compressor			LIGHTS Fans HTRS	EVAP Pan	Total Amps		No Crate	With Crate	L"	W"	H"
					H.P	F.L.A	L.RA									
	KPM-FG-60-S	60	23.47	5.33	1/2	9.6	49	1.42	3.3	14.35	5-20P	494	716	67	44	42
	KPM-FG-80-S	77.5	30.70	8.76	1/2	9.6	49	1.59	3.3	14.52	5-20P	606	866	85	44	42
	KPM-FG-100-S	101.2	40.45	13.41	5/8	8.9	47	4.80	3.3	14.23	5-20P	714	1032	108	44	42

REMOTE	Model	O.A. Length (inches)	Number of Rear Doors	115 Volts Total Amps	B.T.U	Weight lbs	
						No Crate	With Crate
	KPM-FG-60-R	60	1	0.97	2959	438	661
	KPM-FG-80-R	77.5	2	1.14	3253	550	813
	KPM-FG-100-R	101.2	3	0.91	4372	695	1014

Refrigerated Rear Storage Area	L" x W" x H"
KPM-FG-60	27" X 16-47/64"/29-29/64" X 13-25/64"
KPM-CFG-80	44-1/2" X 16-47/64"/29-29/64" X 13-25/64"
KPM-FG-100	68-1/8" X 16-47/64"/29-29/64" X 13-25/64"

STANDARD FEATURES

- Silver colored PVC coated steel front panel
- CFC free injected foam insulation
- PVC coated steel gray interior
- Black steel kick plate
- Rear work bench
- Foamed polystyrene black end panels
- Tempered glass inside shelf is NON-REFRIGERATED
- LED lighting in canopy
- Removable condensate evaporating pan for easy cleaning on self contained units
- Temperature and defrost regulated by a digital controller
- Slide out condensing unit on self-contained units
- Anti condensate system for front glass
- Digital thermometer
- Levelling feet

OPTIONAL FEATURES

- Stainless steel exterior and / or interior
- Other colors available
- Joining Kit
- Partition
- White epoxy bi-level wire racks; 2 or 3 level step sham
- Scale stand with receptable
- Cutting Board
- Knife Support
- Condensate evaporating pan for remote cases
- Casters add 4-3/8" to height
- Stainless steel legs are adjustable from 5-1/8" to 7-5/8"

WARRANTY

One year parts and labor with an additional four years on the compressor (part only)

3560 NW 56th St
Fort Lauderdale, FL USA 33309
Tel: 786.600.4687 / Toll Free: 844.218.8477 / Fax: 786.661.4100

5659 Royalmount Ave.
Montreal, QC, Canada H4P 2P9
Tel: 514.737.9701 / Toll Free: 888.275.4538 / Fax: 514.342.3854
Toll free: 877.453.8832
sales@mvpgroupcorp.com / mvpgroupcorp.com

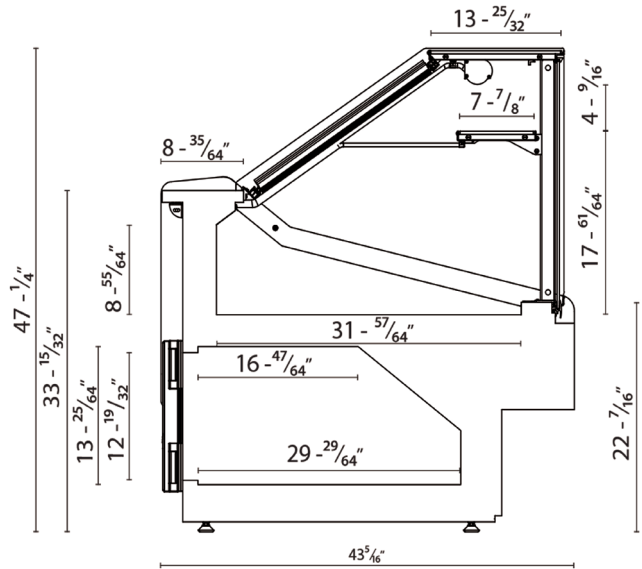

Standard Mounting



Levelling Feet

Optional Mounting



Adjustable Legs



Casters

NOTE

These cases are engineered to operate in locations not exceeding 75°F and 55% R.H. These cases are designed to operate using R452a refrigerant. Alternate refrigerants available by special order. O.A. length includes (2) ends at 1-1/2" each. Ventilation grills at front and back cannot be blocked. B.T.U.'s are calculated at 14°F (evaporator) and 90°F (ambient). Remote case are provided with an expansion valve and a liquid solenoid for pump down cycle. On remote cases, if no floor drain is provided, a condensate evaporating pan must be ordered and 3.3 amps added to the amp load. Remote cases must be hard wired – no plugs.

