

**REFRIGERATOR MANUFACTURER**  
**Turbo air**  
 more durable, efficient, beautiful

4184 E. Conant St.  
 Long Beach, CA 90808  
 Tel. 310-900-1000  
 Fax. 310-900-1077  
[www.turboairinc.com](http://www.turboairinc.com)

Project :	
Model # :	
Item # :	Qty :
Available W/H :	
Approval :	

## Horizontal Open Display Cases

Low Profile  
 Glass Side Panel

### Patented Self-Cleaning Condenser

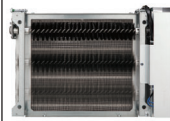

This product is equipped with a fine mesh filter to the front of the condenser to catch dust, and a rotating brush that moves up and down daily to remove excess buildup outward and away.

**Model : TOM-60L-UF-S-3S-N**



### ≡ FEATURES & BENEFITS ≡

#### ▪ Self-Cleaning Condenser

The accumulation of dust in the condenser can cause the failure or breakdown of refrigerators. Refrigerators run normally until they reach a certain level of accumulation. At some point, when they are over the limit, their performance drops quickly resulting in damage to, or disposal of the stored products inside. The Self-Cleaning Condenser device keeps the condenser clean and prevents system failure by automatically brushing daily.

#### ▪ Hydrocarbon refrigerants (R-290)

With innovative and eco-friendly technology, Turbo Air brings you hydrocarbon refrigerators designed to meet DOE's Energy Conservation Standards in 2017 and to use EPA's SNAP Program approved HC refrigerants. Hydrocarbon refrigerants do not deplete the ozone layer and have very low contribution to global warming (ODP-0, GWP-3).

#### ▪ Modern design

By integrating great contours with durable structures, our modern style product designs are user-friendly while maintaining the highest product visibility and aesthetics. Safety reinforced tempered glass front shield and side walls optimize the merchandiser's display effects of fresh salads, sandwiches, desserts and beverages. Its elegant contemporary euro design will enhance any store application.

#### ▪ Designed to enhance impulsive sales

Ideal for eye-catching displays and convenient access with fast service in high traffic area.

#### ▪ Standard back-guard improves airflow

#### ▪ Stainless steel interior standard including back wall and deck pans

#### ▪ Bottom stainless steel solid shelf and glass shelves standard

#### ▪ Perforated interior back wall & open top for improved airflow

#### ▪ Foamed with polyurethane, high-density cell insulation (CFC free)

#### ▪ LED interior lighting

#### ▪ Front air intake and rear air discharge

#### ▪ Energy Saving Curtain Standard



Model	CU./FT.	# of Shelves	HP	AMPS	Crated Weight (lbs.)	L x D x H* (inches)
TOM-60L-UF-S-3S-N	19.3	2	3/4 x 2	15	631	58 3/4 x 33 x 52 1/2

# Horizontal Open Display Cases

Low Profile  
Glass Side Panel

## Model : TOM-60L-UF-S-3S-N

ELECTRICAL DATA	
Voltage	115/60/1
Plug Type	Ⓢ NEMA 5-20P
Full Load Amperes	15
Compressor HP	3/4 x 2
Cord Length (ft.)	97/8
Refrigerant	R-290
DIMENSIONAL DATA	
Net Capacity (cu. ft.)	19.3
Ext. Dimension (L x D x H") (in.)	58 <sup>3</sup> / <sub>4</sub> x 33 x 52 <sup>1</sup> / <sub>2</sub>
Int. Dimension (L x D x H) (in.)	56 <sup>3</sup> / <sub>8</sub> x 23 <sup>1</sup> / <sub>2</sub> x 25 <sup>1</sup> / <sub>4</sub>
# of Shelves	2
Shelf Size (L x D) (in.)	55 <sup>5</sup> / <sub>8</sub> x 10, 55 <sup>5</sup> / <sub>8</sub> x 14
Net Weight (lbs.)	526
Gross Weight (lbs.)	631

Design and specifications subject to change without notice.  
Actual shipping weight may differ due to extra packing materials for product protection.  
\* Height does not include 5/8" for bolt height.

### ■ WARRANTY : 2 Year Parts and Labor Warranty Additional 3 Year Warranty on Compressor

### ■ STANDARD FEATURES

- Simple plug-in installation
- No plumbing required
- Solar powered digital thermometer
- Digital electronic thermostat with defrost control
- Bolt height adjustable up to 2<sup>3</sup>/<sub>4</sub>"

\*\* Lead time applies. Please contact your sales representative for more details to order.

### ■ Recommended operating conditions

TOM models are designed to operate in an environment where temperature & humidity do not exceed 80°F and 55% respectively. Units should not be installed near HVAC vents, fans or doorways that will disrupt the air curtain and compromise the function of the cabinet. Air curtain models will run most efficiently when completely loaded with product. When used as a built-in, required clearance for the rear is 4" and the top is 5".

### ■ OPTIONAL ACCESSORIES

- 1.6" caster: CAS16WBT00 (non-brake)
- 4" caster, 1/2" diameter & 13 TPI: G8F6500101 (non-brake), G8F6500201 (w/ brake)
- 6" leveling seismic leg (1/2", 13 TPI): 30221M0700

## PLAN VIEW

(unit : inch)

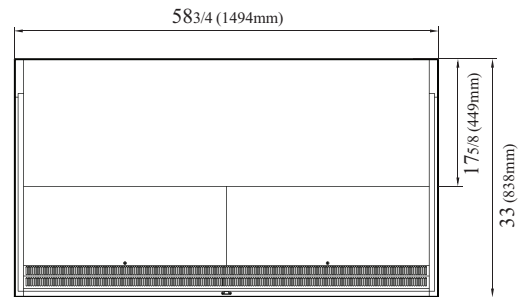

TOP VIEW

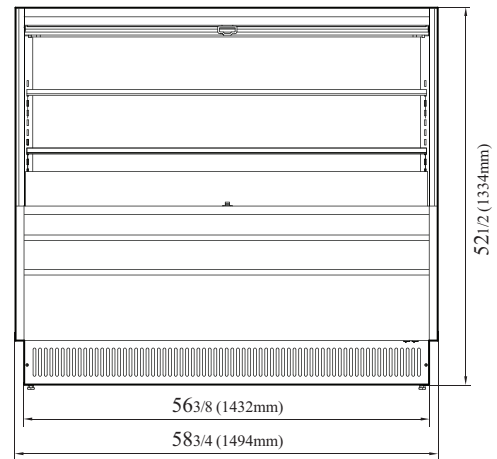

FRONT VIEW

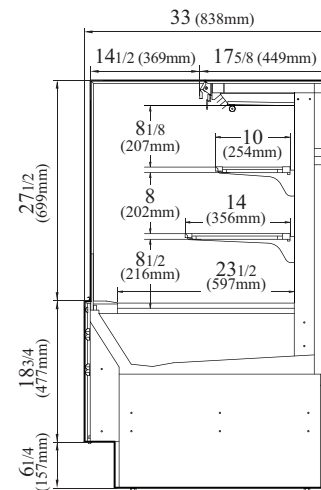

SIDE VIEW

Ver.20200526



- Turbo Air : 800-627-0032
- GK : 800-500-3519
- Warranty : 800-381-7770
- AC : 888-900-1002

REFRIGERATOR MANUFACTURER  
**Turbo air**

GERMAN  
KNIFE

RADIANCE

REFRIGERATION SYSTEM  
**Turbo air**

**Texaking**